

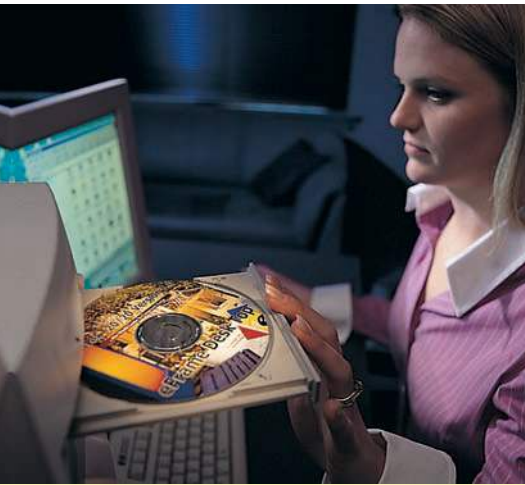

MiTEK®
ROOF AND
FLOOR TRUSS
MANUAL

FOR
ARCHITECTS
AND ENGINEERS





Headquartered in St. Louis, Missouri, MiTek Industries, Inc. is the leading supplier of connector plates, truss manufacturing equipment, design software, and engineering services for the worldwide component industry.

For over 35 years MiTek companies have developed and refined their connector plates into the state-of-the-art products they are today...consistent and dependable!

With MiTek you're assured of the best quality. MiTek connector plates are manufactured under strict quality control and undergo extensive testing in our R & D facility.

MiTek's connector plates meet or exceed all building code and industry association requirements. Acceptances include BOCA, ICBO, HUD/FHA, SBCCI, Dade County, Wisconsin/ DILHR, and LA City.

MiTek also offers the very best in framing layout and engineering software for roof and floor trusses, as well as wall panel design. These programs provide our fabricators with fast and accurate layout and design capabilities.

Our engineering department is available to review and seal our customers' designs. With offices in NC, Missouri and California, MiTek's professional engineers can furnish seals for all 50 states!

Look to a MiTek fabricator for the best the industry has to offer! This brochure reviews the benefits of roof and floor trusses, but MiTek fabricators also offer a full line of builders hardware and a complement of other building components including wall panels and steel framing.

At MiTek, we are committed to providing the best products and services in the industry and will continue our tradition of customer support.

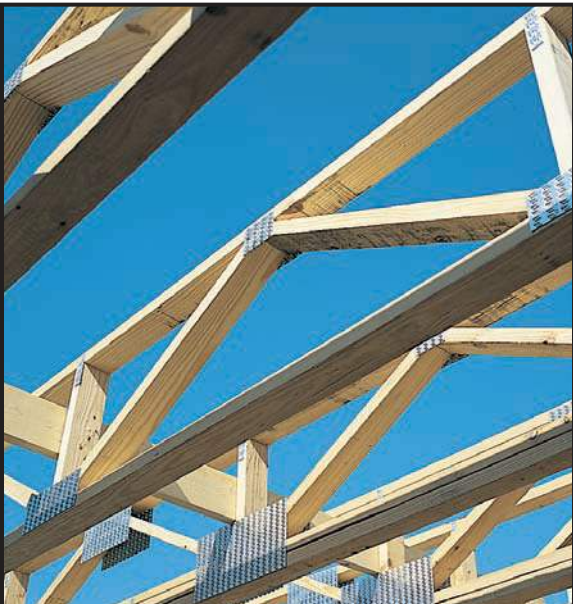

TABLE OF CONTENTS

PAGE NO.

Introduction	2
Wood Truss Advantages	3
Truss Advantages	3
Handling, Installation and Bracing	4
Basic Roof Truss Configurations	5-6
Construction Details	
Support Details	7
Joint Details	8
Lateral Bracing Information	9
Cantilever Framing	10
Stairway Framing	11
Technical Information	
Architectural Specifications	12
Recommended Depth, Deflection and Camber Limitations	12
Construction Guidelines	12
Mechanical Service Guidelines	13
Cantilever Concentrated Loads	13
Floor Decking Information	14
Connector Plate Code Approvals	14
Fire Rating Information	15
Sound Transmission Ratings	16
Construction Material Weights	16
Representative Floor and Roof Loads	16
Floor Loading Max-Span Information	16
Floor Loading Max-Span Tables	17
Glossary of Terms	18-19

WHY USE WOOD TRUSSES? CONTRACTORS AND BUILDERS KNOW!



ADVANTAGES OF TRUSSES OVER CONVENTIONAL FRAMING...

Contractors and Builders know that a MiTek engineered roof or floor truss system ensures quality and efficiency.

MITeK TRUSSES SAVE MONEY

Because costs are known in advance, there's no guesswork. Your site erection time is greatly reduced and dollar losses from job site material shortages and pilferage are eliminated.

MITeK TRUSSES ARE RELIABLE

Every MiTek truss has been individually designed and that design is checked and approved by certified engineers for structural adequacy.

MITeK TRUSSES Are Versatile

MiTek trusses provide more design flexibility, inside and out, than conventional framing. Offering numerous custom design options, our trusses present an economical and structurally superior method for rapid erection.

ARCHITECTS AND DEVELOPERS

- ◆ Savings in design costs-one basic structural design for shell with minor floor plan variations.
- ◆ Better project cost control, with component costs known in advance.
- ◆ Better cash flow with earlier occupancy due to reduced on-site labor.
- ◆ Faster shell completion time.
- ◆ Using trusses of smaller dimension lumber, in place of beams and columns.
- ◆ Greater flexibility in locating plumbing, duct work, and electrical wiring.
- ◆ Floor plan freedom in locating interior partitions often without additional support required.

CONTRACTORS/ BUILDERS

- ◆ Pre-determined, pre-engineered truss system.
- ◆ Fewer pieces to handle and reduced installation time.
- ◆ Wide 3-1/2" nailing surface for easy floor deck application.
- ◆ Eliminate notching and boring joists for electrical wiring and plumbing.
- ◆ Floor trusses offer better availability and less in-place cost than 2x8 or 2x10 joists.
- ◆ Factory-manufactured components to exact span requirements.
- ◆ Reduced HVAC, plumbing, and electrical subcontractor time on job.
- ◆ No column pads to pour, no steel beams and posts to place.
- ◆ Job site material pilferage and cutting waste reduced.

HOMEOWNER

- ◆ Lower construction costs.
- ◆ Clearspan flexibility.
- ◆ More flexibility in architectural appearance and floor plans.
- ◆ Easier remodeling possibilities in moving interior walls.

HANDLING INSTALLATION AND BRACING*

It is the responsibility of the installer to select the most suitable method and sequence of installation available to him which is consistent with the owner's (architectural) plans and specifications and such other information which may be furnished to him prior to installation. Trusses may be installed either by hand or by mechanical means. The method generally depends upon the span of the trusses, their installed height above grade, and/or the accessibility or availability of mechanical installation equipment (such as a crane or forklift).

The installer should be knowledgeable about the truss design drawings, truss placement plans, and all notes and cautions thereon.

TEMPORARY BRACING

Temporary or installation bracing is the responsibility of the installer. Temporary bracing should remain in place as long as necessary for the safe and acceptable completion of the roof or floor and may remain in place after permanent bracing is installed.



STORAGE

Trusses should be stored in a stable position to prevent toppling and/or shifting.

If trusses are stored horizontally, the blocking should be eight to ten foot centers to prevent lateral bending. If the truss bundle is to be stored for more than one week, the solid-blocking, generally provided by the receiving party, should be at a sufficient height to lessen moisture gain from the ground.

During long-term storage, trusses should be protected from the elements in a manner that provides for adequate ventilation of the trusses. If tarpaulins or other water resistant materials are used, the ends should be left open for ventilation. If trusses are made with interior rated fire retardant lumber, extreme care should be taken to limit outside exposure.

FIELD ASSEMBLY

In some cases, the size or shape of wood trusses is such that some field assembly is required. The installer is responsible for proper field assembly.

Complete details on handling, installing and bracing can be found in the Truss Plate Institute (TPI) publications HIB-91 and DSB 89, available from TPI, 583 D'Onofrio Drive, Suite 200, Madison, WI 53719.

*Reprinted from the "Commentary & Recommendation for Handling, Installing & Bracing, Metal Plate Connected Wood Trusses, HIB-91", by permission of Truss Plate Institute, Inc.

TRUSS TYPES

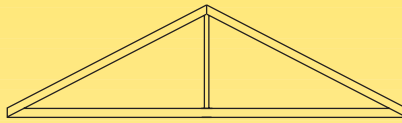
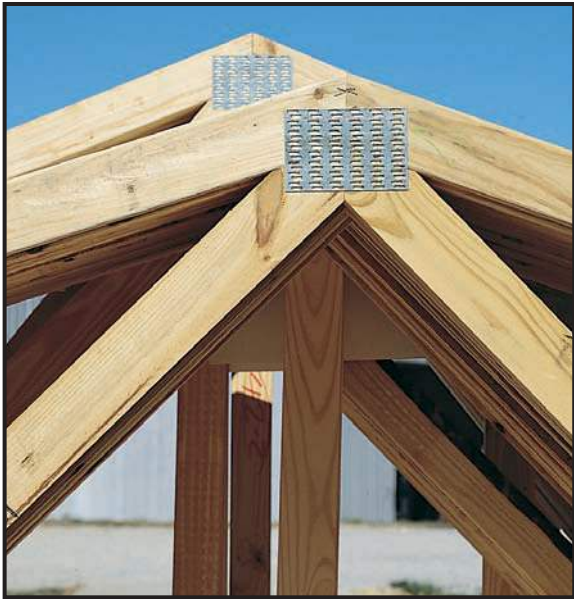

KINGPOST

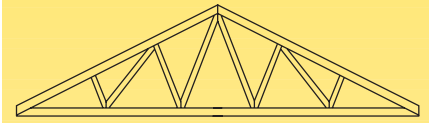

DOUBLE FINK

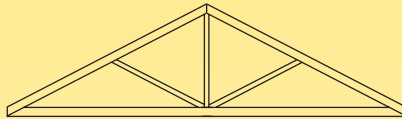

QUEENPOST

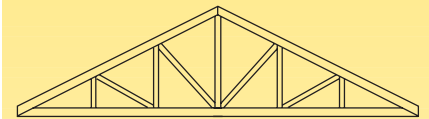

DOUBLE HOWE

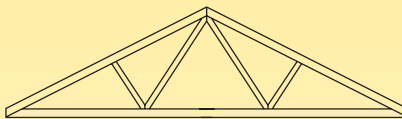

FINK

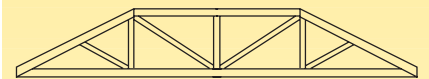

HIP

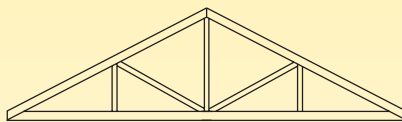

HOWE

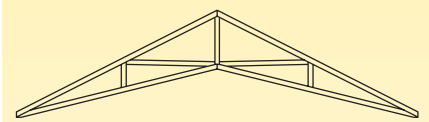

SCISSORS

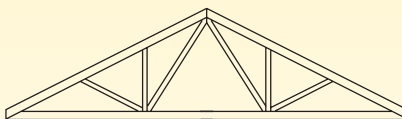

FAN

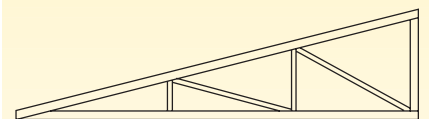

MONOPITCH

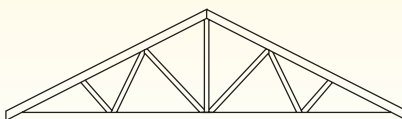

MODIFIED QUEENPOST

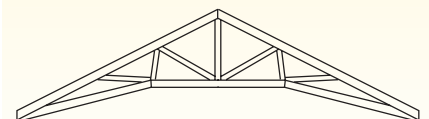

CAMBERED

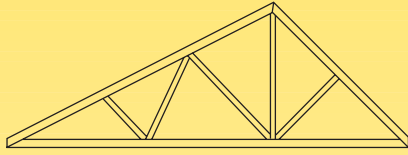

DUAL PITCH

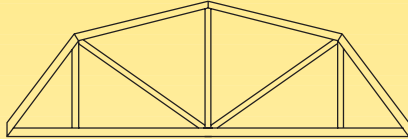

GAMBREL

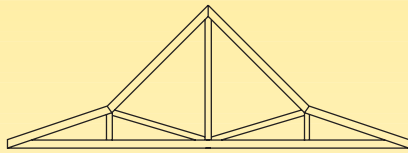

POLYNESIAN

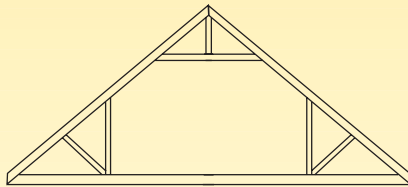

ATTIC

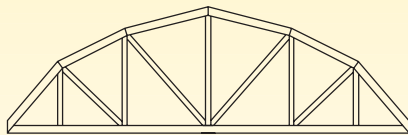

BOWSTRING

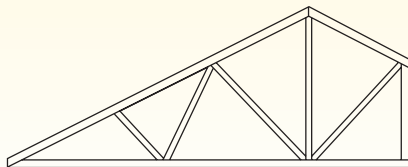

STUB

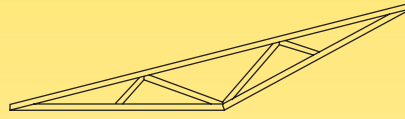

INVERTED

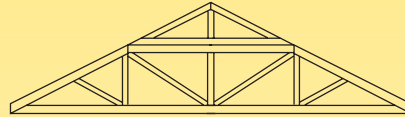

PIGGYBACK

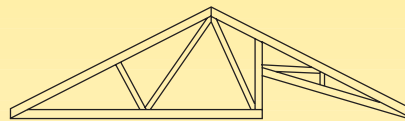

STUDIO

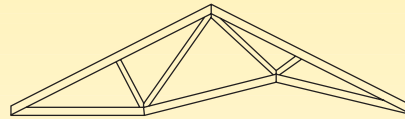

CATHEDRAL

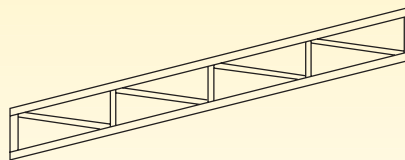

SLOPING FLAT

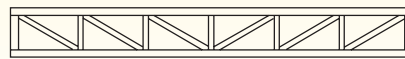

FLAT



SUPPORT DETAILS

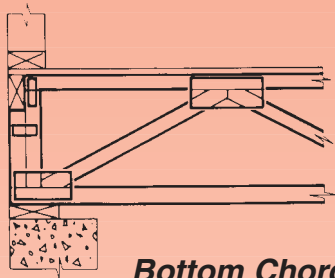

Bottom Chord Bearing on Exterior Frame or Masonry Wall

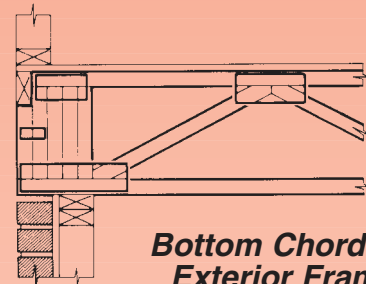

Bottom Chord Bearing on Exterior Frame Wall with Masonry Fascia Wall

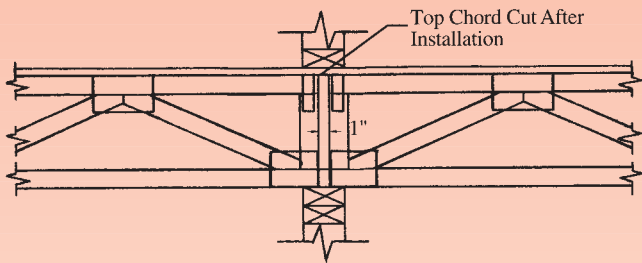

Intermediate Bearing - Simple Span Trusses

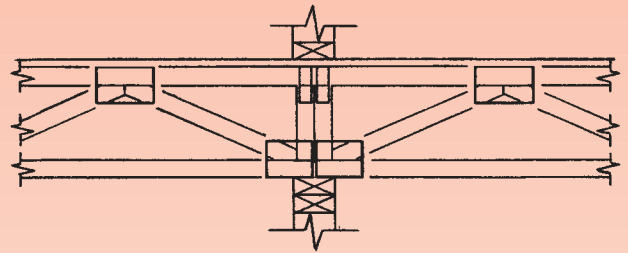

Intermediate Bearing - Continuous Floor Truss (Special Engineering Required)

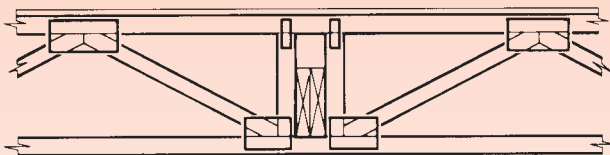

Header Beam Pocket - Floor Truss Supporting Header Beam (Special Engineering Required)

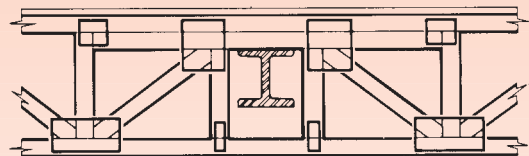

Intermediate Bearing - Floor Truss Supported by Steel or Wood Beam (Special Engineering Required)

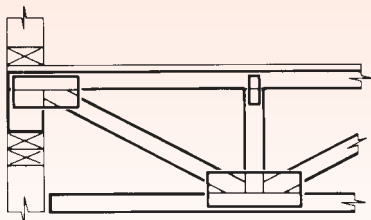

Top Chord Bearing on Frame Wall

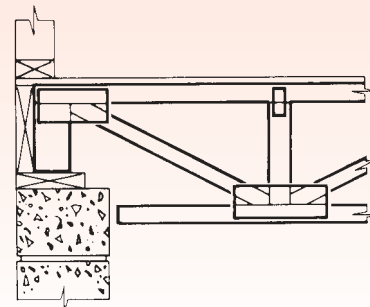

Top Chord Bearing on Masonry Wall

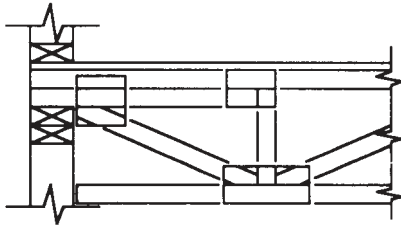

Extended Top Chord Bearing
(Span Limited by Engineering)

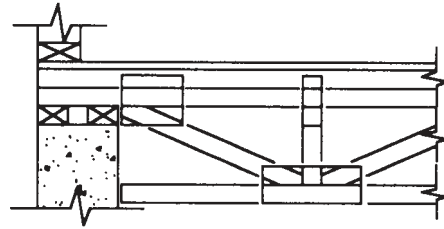

Extended Top Chord Bearing
(Span Limited by Engineering)

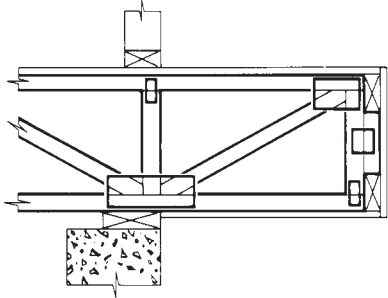

Balcony Cantilever

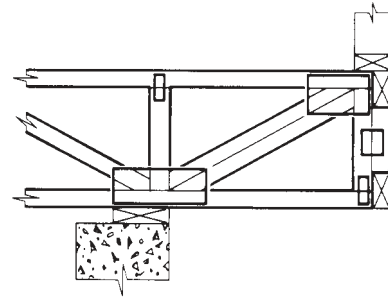

Load-Bearing Wall Cantilever

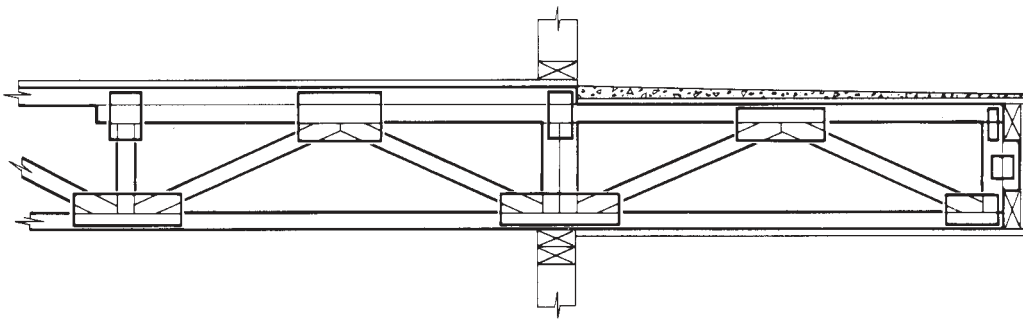

Dropped Chord Balcony Cantilever

JOINT DETAILS

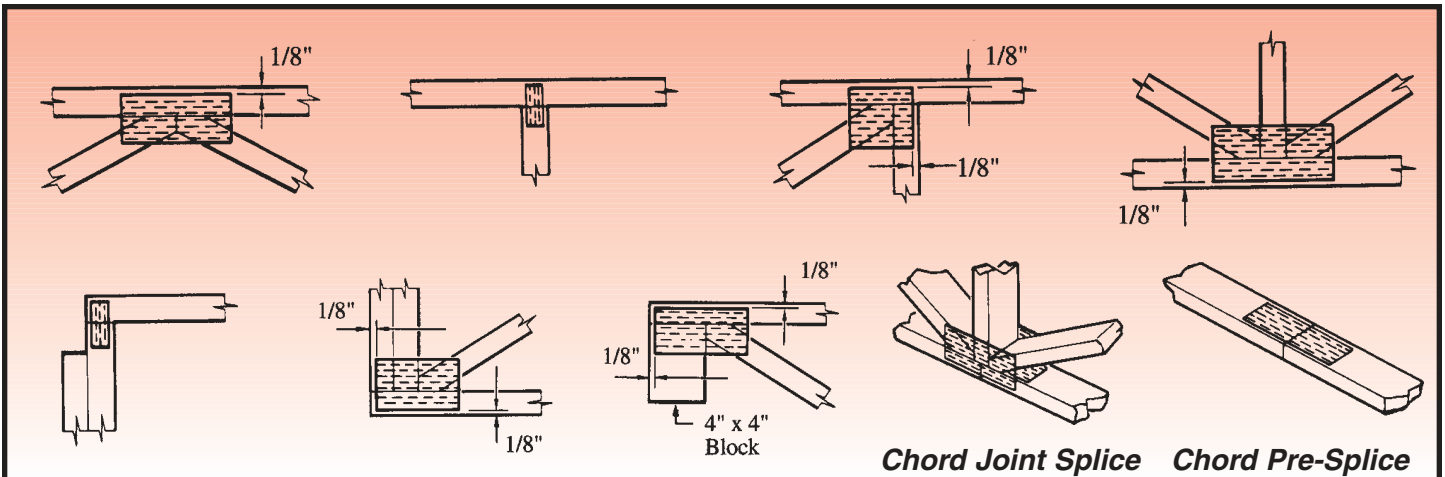

Chord Joint Splice Chord Pre-Splice

LATERAL BRACING SUGGESTIONS

2x6 "Strongback" lateral supports should be located on edge approximately every 10 feet along the floor truss. They should be securely fastened to vertical webs. Blocking behind the vertical web is recommended while nailing the strongback. The strongbacks should either be secured to adjacent partition walls or alternate "X"-bridging should be used to terminate the bracing member.

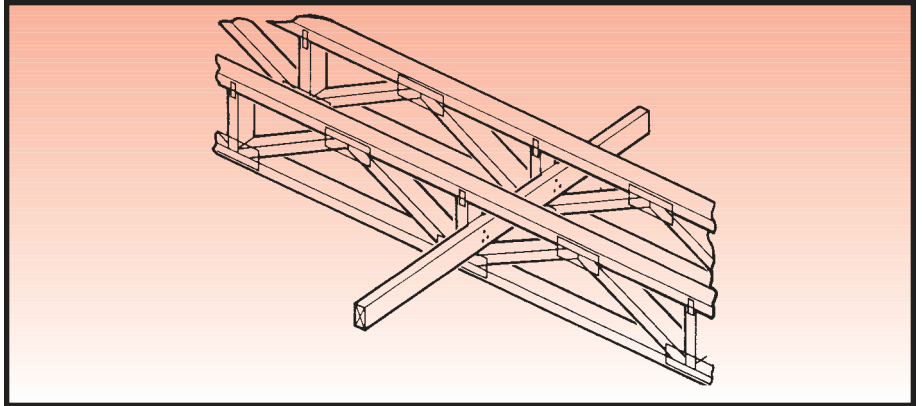

Floor Cantilevered Perpendicular to Floor Truss Span

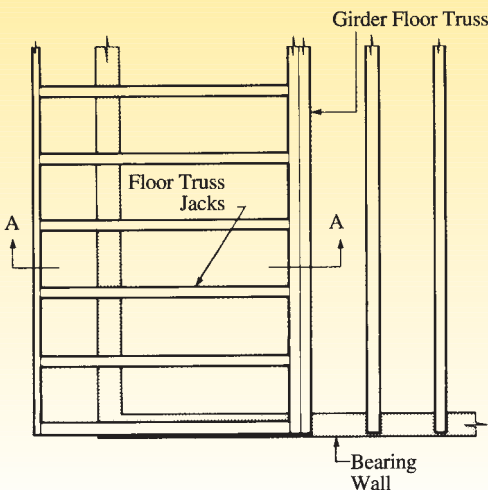

Floor Cantilevered Perpendicular and Parallel to Floor Truss Span

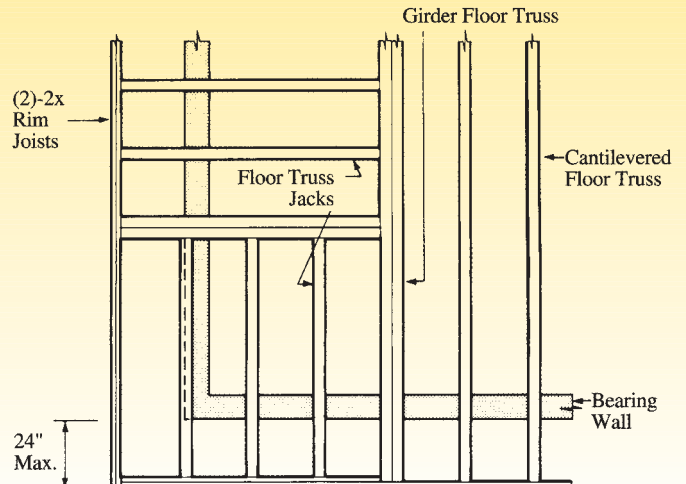

Section AA - Floor Truss Jacks

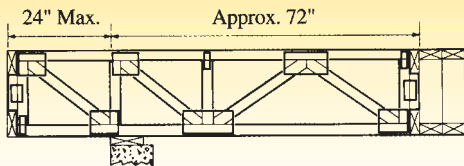

Floor Joist Scab Cantilever

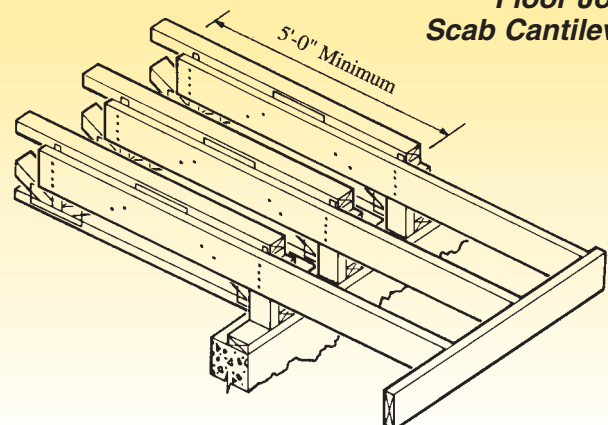

Notes

- Special engineering required for girder floor trusses.
- Slope for drainage, as required.
- Cantilever span controlled by lumber size and grade deflection limitations.

STAIRWAY FRAMING

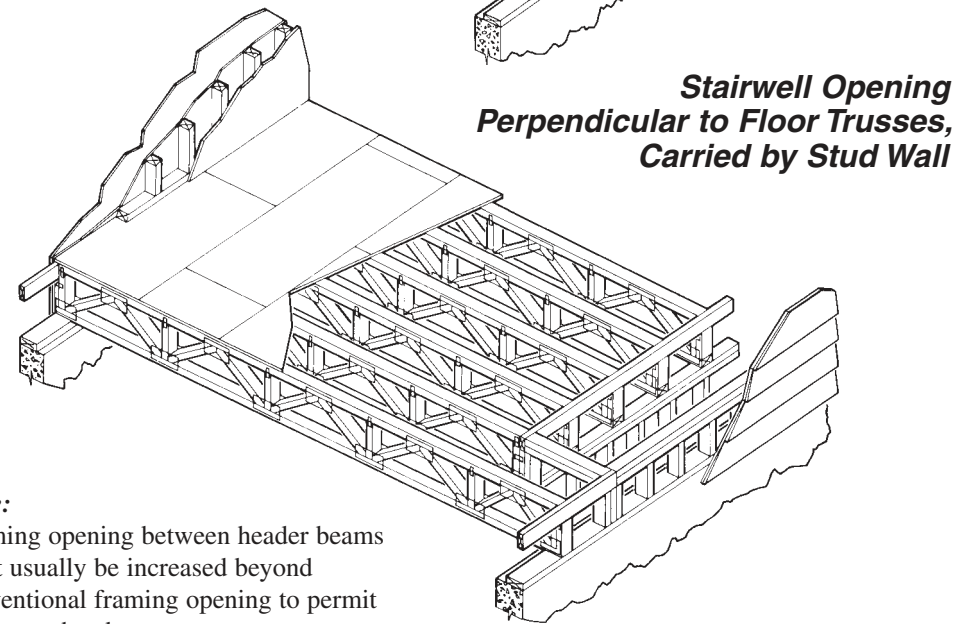
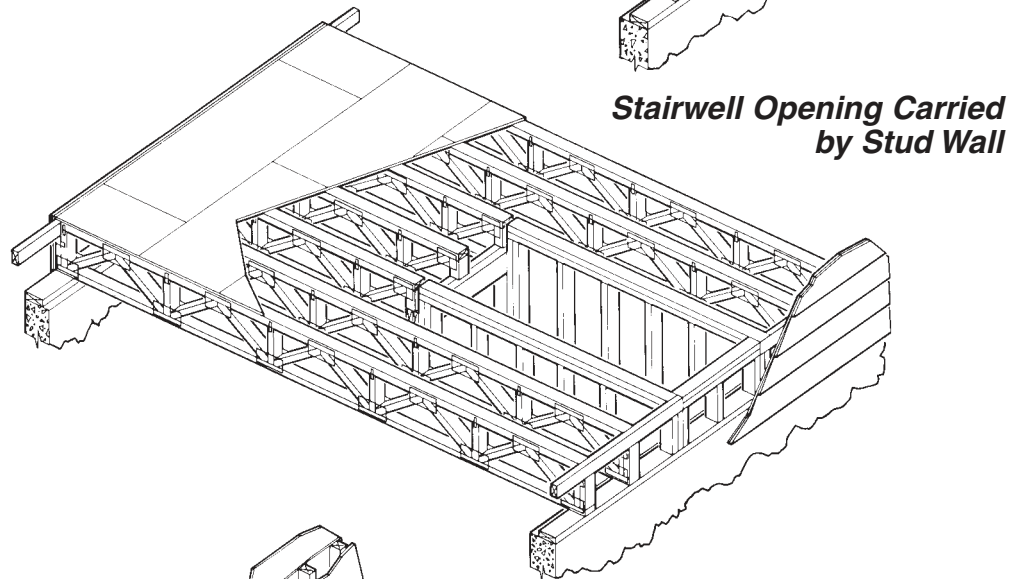
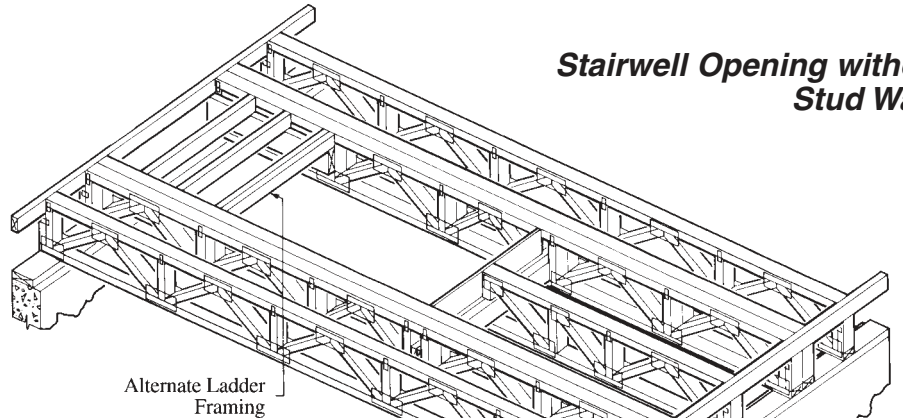
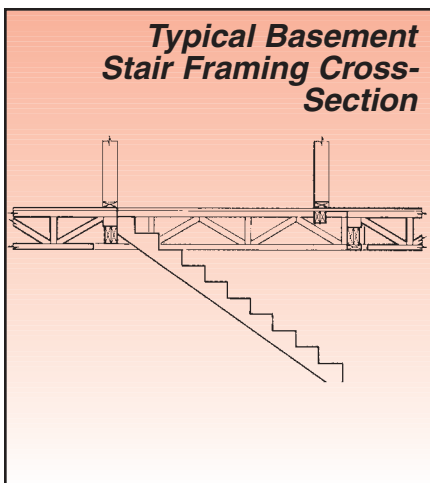
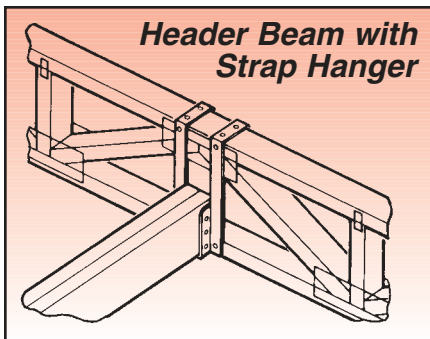
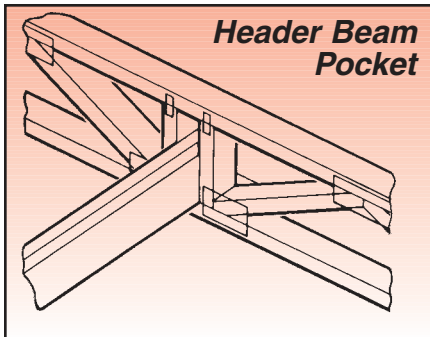
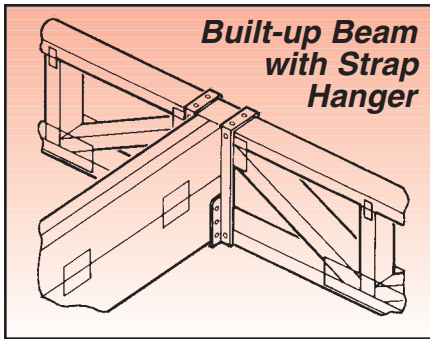

Note:
Framing opening between header beams must usually be increased beyond conventional framing opening to permit necessary headroom.

ARCHITECTURAL SPECIFICATION

- ◆ Trusses shall be fabricated by a MiTek truss manufacturer in accordance with MiTek floor truss engineering specifications.
- ◆ MiTek engineering design drawings bearing the seal of the Registered Engineer preparing the design shall be provided to the Project Architect for his approval.
- ◆ Truss designs shall be in accordance with the latest version of ANSI/TPI1 National Design Standard for Metal Plates Converted Wood Construction, a publication of Truss Plate Institute and generally accepted engineering practice.
- ◆ Delivery, handling, and erection of MiTek trusses shall be in accordance with the “TPI Quality Standard for Metal Plate Connected Wood Trusses,” published by Truss Plate Institute.
- ◆ Truss hangers, anchorage, permanent bracing, and required design loads shall be the responsibility of the Project Architect.
- ◆ MiTek truss connector plates are manufactured under rigid quality control using structural Grade C hot-dipped, galvanized steel meeting ASTM Specifications A653.

RECOMMENDED DEPTH, DEFLECTION, AND CAMBER LIMITATIONS

In addition to allowable lumber stress limitations, floor truss designs are also regulated by maximum permissible deflection-to-span and depth-to-span limitations, as shown in the chart below. The suggested camber to be built into the truss during fabrication is also included. The truss deflection is calculated by

complex engineering methods and verified by extensive full-scale load tests. The floor span-to-depth limitation is intended to prevent objectionable floor vibration. All of the following recommended limitations should be achieved to provide a quality floor system and assure complete customer satisfaction.

	Floor	Roof
Minimum Depth	Span/20	Span/24
Maximum Deflection	Span/360 (Live Load)	Span/240 (Live Load)
Recommended Camber	Dead Load Deflection	Dead Load Deflection*

* Provide slope of 1/4" per foot of span for proper drainage to prevent water ponding.

CONSTRUCTION GUIDELINES

ROOFS

DON'T Unload trusses on rough terrain or uneven surfaces, which could cause damage to the trusses.

DO support trusses that are stored horizontally on blocking to prevent excessive lateral bending and lessen moisture gain.

DON'T break banding until installation begins and the trusses are in a stable, horizontal position.

DON'T lift bundled trusses by the bands and do not use damaged trusses.

DO brace trusses that are stored vertically, to prevent toppling or tipping.

DON'T walk on trusses that are lying flat. This is a dangerous practice.

FLOORS

DO color-code floor truss ends for correct non-symmetrical installations.

DO locate trusses to allow for plumbing or duct riser clearances.

DO assure that trusses are installed with a joint located over an interior bearing.

DO use warning tags on floor trusses to provide proper installation orientation and to warn against cutting or modifying trusses.

DON'T permit stacking of drywall or plywood sheathing during construction on floor truss balcony cantilevers or at truss mid-span without proper shoring.

DON'T use floor trusses when exposed to weather, chemically corrosive environment, or extremely high humidity.

DON'T cut truss chords or webs or modify them in any way during construction.

MAXIMUM MECHANICAL SERVICE CLEARANCES - FLOOR TRUSSES

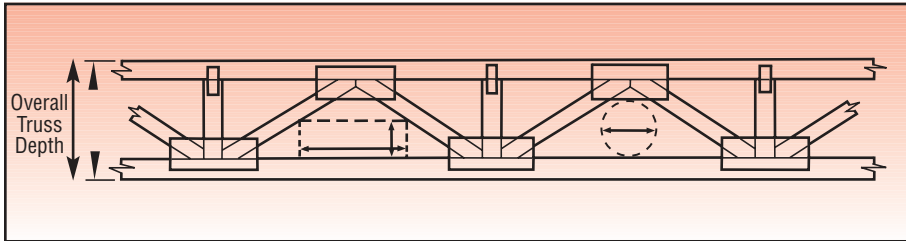

Overall Truss Depth (Inches)	Width (W) (Inches)						Diameter (D) (Inches)
	When Height (H) Equals:						
	3"	4"	5"	6"	7"	8"	
12	32	25	19	12	6	-	7
13	34	28	23	17	11	5	8
14	36	31	26	20	15	10	9
15	38	33	28	23	19	14	10
16	40	35	31	26	22	17	11
17	41	37	32	28	24	20	12
18	42	38	34	30	26	22	13
19	43	39	36	32	28	25	14
20	44	40	37	33	30	26	15
21	44	41	38	35	31	28	16
22	45	42	39	36	33	30	17
23	46	43	40	37	34	31	18
24	46	43	41	38	35	32	18-1/2

FLOOR TRUSS CANTILEVER CONCENTRATED LOADS

Floor truss cantilevers often support load-bearing walls carrying roof live loads and wall material dead loads. The adjacent chart provides a convenient means of determining an equivalent concentrated load for representative roof loads which incorporate a 15% load duration factor for the roof load only.

Roof Span (Feet)	Concentrated Load at End of Cantilever (lbs.)		
	Roof Load (at 1.15) Plus Wall Load		
	20/10/0/10 = 40 psf	30/10/0/10 = 50 psf	40/10/0/10 = 60 psf
20	865	1040	1215
22	965	1125	1320
24	1005	1215	1425
26	1075	1300	1530
28	1145	1385	1630
30	1215	1475	1735
32	1285	1560	1840

CONCENTRATED LOAD SAMPLE CALCULATION

Roof Loading = 20/10/0/10 = 40 psf @ 1.15

Roof Load (Roof Truss Reaction) = 40 psf x (30'/2) x 2'-0" o.c. - 1200 lbs.
 8' Stud Wall Weight (@ 85 lbs./lineal ft.) = 85 plf x 2'-0" o.c. = 170 lbs.

Equivalent Floor Truss Load = (1200/1.15) + 170 = 1215 lbs. Concentrated Load

Note:

Also check floor truss for dead load only at end of cantilever.

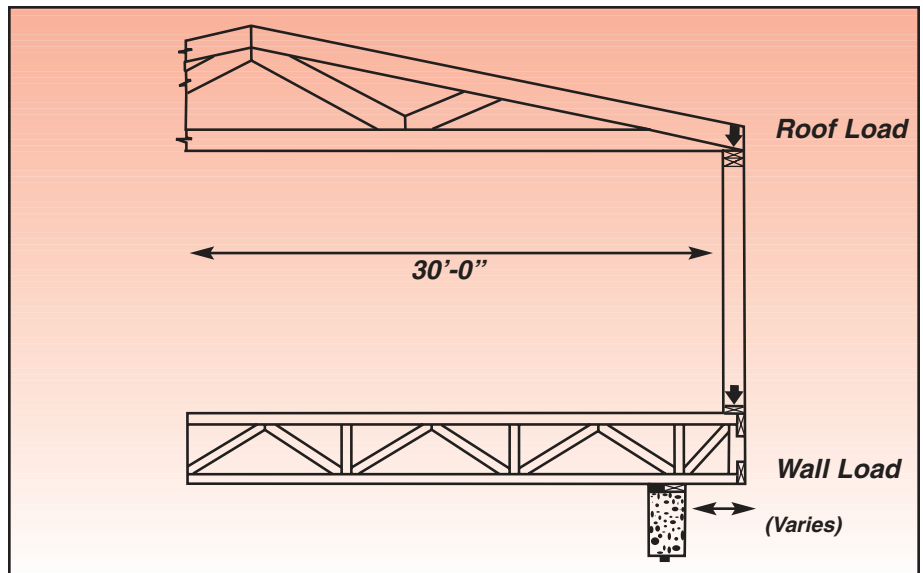

FLOOR DECKING INFORMATION

Virtually all decking systems may be easily applied to MiTek floor trusses. The wide 3-1/2" nailing surface assures that floor decks are installed accurately and quickly. The adjacent table is a summary of plywood deck requirements presented by various American Plywood Association publications.

Floor Construction	Panel Indent	Thickness	Floor Truss Spacing
Conventional Double-Layer Plywood Underlayment over Plywood Sub-Flooring	48/24 40/20 32/16 24/16	23/32", 3/4", 7/8" 19/32", 5/8", 3/4", 23/32" 15/32", 1/2", 5/8", 19/32" 7/16", 15/32", 1/2"	24" Spacing 19.2" Spacing 16" Spacing 16" o.c. Spacing
Wood Strip Flooring over Plywood Sub Flooring (installed at right angles)	32/16 40/20	15/32", 1/2", 5/8", 19/32" 19/32", 5/8", 3/4", 23/32"	24" Spacing Permitted
1-1/2" to 2" Lightweight Concrete Cap over Plywood Subflooring	40/20	19/32", 5/8", 3/4", 23/32"	24" Spacing Permitted
APA Sturd 1-Floor (must be nailed or glued and nailed according to APA)	24 20 16 32 48	23/32", 3/4", 7/8" 19/32", 5/8" 19/32", 5/8" 7/8", 1" 1-1/8"	(Spacing equal to Panel Indent.) Panels must either be Tongue-and-Groove or blocked Between Trusses.
APA Glued Floor System (must be glued according to APA Spec. AFG-01 and nailed)	24" Spacing 19.2" Spacing 16" Spacing	(Available thickness for either conventional subflooring plywood or for Sturd-I-Floor Panels.)	

CONNECTOR PLATE CODE APPROVALS

MiTek connector plates have been approved by all recognized national and regional model building code groups, based on extensive structural testing. The following approvals may be referenced for more detailed information:

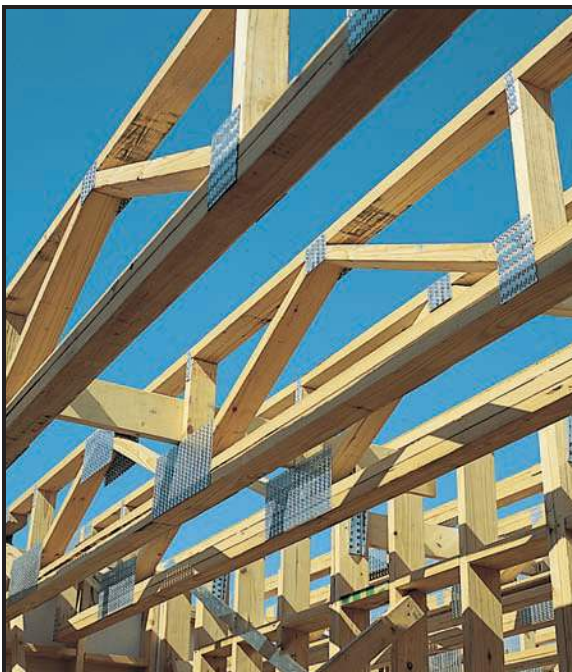

- ◆ **BOCA National Building Code**
Building Officials and Code Administrators, International (BOCA) Research Report No. 96-31, 96-67
- ◆ **Uniform Building Code (UBC)**
International Conference of Building Officials (ICBO) Report No. 3907 and 4922.
- ◆ **Standard Building Code (SBC)**
Southern Building Code Congress International (SBCCI) Report No. 9667 and 9432A.
- ◆ **Federal Housing Administration (FHA/HUD)**
U.S. Department of Housing and Urban Development (HUD) Truss Connector Bulletin No. TCB 17.08.
- ◆ **Wisconsin State Code**
Wisconsin Department of Industry, Labor and Human Relations (DILHR) Approval No. 960022-W, 970036-N.

FLOOR TRUSS ONE-HOUR FIRE RATING

The Truss Plate Institute has authorized fire tests be conducted to achieve a one-hour fire rating for a typical floor and ceiling assembly. Copies of those reports are available from the issuing agencies.

Additional information regarding one-hour fire ratings using wood trusses with gypsum board ceiling may be obtained from ICBO Research Reports No. 1632 and 1352.

Fire rating test results are summarized in the adjacent illustrations.



ICBO* Design No. 4431

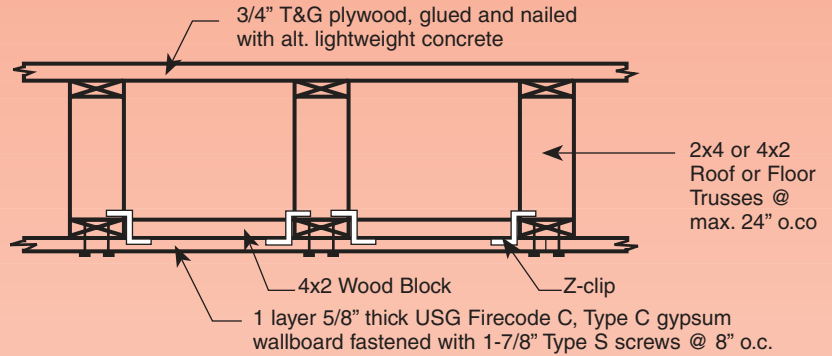

UL** Design No. L528

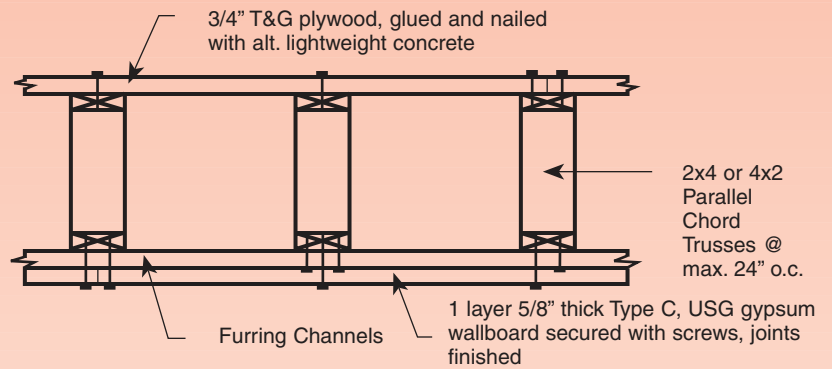

UL** Design No. L529

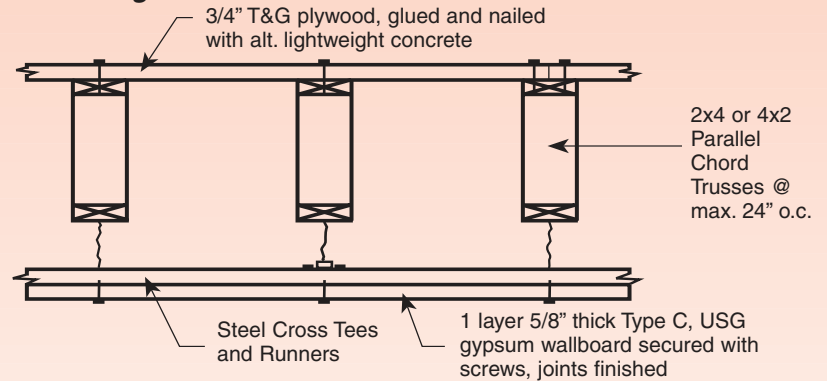

Factory Mutual*** Design FC214

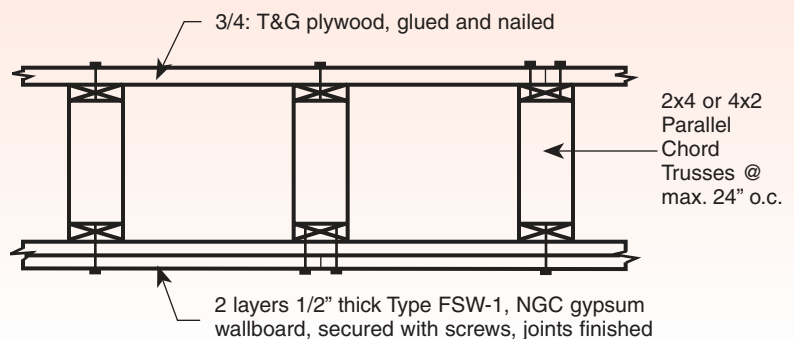

* International Conference of Building Officials
1313 East 60th Street • Chicago, IL 60637

** Underwriters Laboratory, Inc.
333 Pfingsten Road • Northbrook, IL 60062

*** Factory Mutual Research
1151 Boston-Providence Road • Norwood, MA 02062

SOUND TRANSMISSION RATINGS



Various floor-ceiling systems exhibit different abilities to reduce sound transfer from one room to another. This sound transmission resistance is measured by two indices - the Sound Transmission Class (STC) which rates airborne sounds to evaluate the comfortability of a particular living space and the Impact Insulation Class (IIC) which rates the impact sound transmission performance of

an assembly. These ratings are used by regional building codes to regulate permissible sound transfer. For more detailed information reference the Metal Plate Connected Wood Truss Handbook, ©1993 Wood Truss Council of America, Section 18.0 - Transitory Floor Vibration and Sound Transmission.

Calculation Example

Description	STC	IIC
Carpet and Padding	0	20
3/4" Gypcrete	7	1
Wood Truss Floor	36	33
Resilient Channel	10	8
Total	53	62

Description	STC High Frequency	IIC Low Frequency
Basic Wood Floor - consisting of wood joist (I-joist, solid-sawn, or truss), 3/4" decking and 5/8" gypsum wallboard directly attached to ceiling	36	33
Cushioned Vinyl or Linoleum	0	2
Non-cushioned Vinyl or Linoleum	0	0
1/2" Parquet Flooring	0	1
3/4" Gypcrete® or Elastizel®	7-8	1
1-1/2" Lightweight Concrete	7-8	1
1/2" Sound Deadening Board (USG)*	1	5
Quiet-Cor® Underlayment by Tarkett, Inc*	1	8
Enkasonic® by American Enka Company*	4	13
Sempafloor® by Laminating Services, Inc.*	1	11
R-19 Batt Insulation	2	0
R-11 Batt Insulation	1	0
3" Mineral Wood Insulation	1	0
Resilient Channel	10	8
Resilient with Insulation	13	15
Extra Layer of 5/8" Gypsum Wallboard	0-2	2-4
Carpet and Padding	0	20-25

*Estimates base on proprietary literature. Verify with individual companies. The above chart information was excerpted from the Construction Guide for Southern Pine Joist & Rafters. Southern Pine Council, 1993.

TYPICAL CONSTRUCTION MATERIAL WEIGHTS

Floors

Hardwood (1 in. thick)..... 3.8 psf
 Concrete
 Regular (1 in. thick)..... 12.0 psf
 Lightweight (1 in. thick)..... 8.0 psf
 Linoleum 1.5 psf
 3/4" ceramic or quarry tile 10.0 psf

Ceilings

Acoustical fiber tile 1.0 psf
 1/2 in. gypsum board 2.0 psf
 5/8 in. gypsum board 2.5 psf
 Plaster (1 in. thick) 8.0 psf
 Metal suspension system 0.5 psf
 Wood suspension system 2.0 psf

Miscellaneous

Sprinkling system 1.0 to 1.5 psf

Ductwork (24g) 3.0 to 5.0 psf
 Rigid fiberglass (1 in. thick) 1.5psf
 Roll or batt insulation (1 in.) .. 0.3 psf
 Glass or rock wool (1 in. thick).. 0.3 psf
Floors Truss Weights
 Single chord 5.5 plf (approx.)
 @ 24" o.c. spacing .. 2.75 psf (approx.)
 Double chord 8.5 plf (approx.)
 @ 24" o.c. spacing .. 4.25 psf (approx.)

Composition Roofing

235 lb. shingles and paper 2.5 psf
 2-15 lb. and 1-90 lb. 1.7 psf
 3-15 lb. and 1-90 lb. 2.2 psf
 3-ply and gravel 5.6 psf
 4-ply and gravel 6.0 psf

Roof and Floor Sheathing And Decking

1/2 in. plywood 1.5 psf
 5/8 in. plywood 1.8 psf

3/4 in. plywood 2.3 psf
 1-1/8 in. plywood 3.4 psf
 1 in. sheathing (nominal) 2.3 psf
 2 in. decking 4.3 psf
 Tectum (1 in. thick) 2.0 psf
 Poured gypsum (1 in. thick) ... 6.5 psf
 Vermiculite concrete (1 in. thick)
 2.7 psf

Partition Wall Weights (8' Nominal Height)

Interior partition - (studs @ 16" o.c.)..
 50 plf (approx.)
 Exterior partition - (studs @ 16" o.c.)
 and composition exterior).....
 85 plf (approx.)
 Exterior partition - (studs @ 16" o.c.
 and brick exterior) .. 180 plf (approx.)

REPRESENTATIVE FLOOR AND ROOF APPLIED LOADS



Residential Flooring

40 psf Tc live Load
 10 psf TC Dead Load (3/4" plywood decking)
 0 psf BC Live Load
 5 psf BC Dead Load (1/2" to 5/8" drywall)
 55 psf Total Load
 (If heavy insulation or 2-ply drywall ceiling, BC Dead Load = 10 psf and 40/10/0/10 = 60 psf Total Load)

Commercial (Also Multi-Family Dwellings)

40 psf TC Live Load
 25 psf TC Dead Load (1-1/2" to 2" thick lightweight concrete cap)
 0 psf BC Live Load
 10 psf BC Dead Load
 75 psf Total Load

Notes:

- ◆ Above representative loads are typical loading requirements for many regions in the country. However, the required applied loading for design purposes is the responsibility of the building designer, within the limitations of the prevailing local, state, or regional building code specifications.
- ◆ Roof trusses to be checked for local wind loadings.
- ◆ Commercial floors may require additional load cases.

Commercial Floors (Concrete deck)

50 psf TC Live Load (commercial use)
 35 psf TC Dead Load (3" concrete floor)
 0 psf BC Live Load
 10 psf BC Dead Load
 95 psf Total Load

Residential and Commercial Roofing

20, 25, 30, 40, 50 psf TC Live Load (dependent on local building code requirements)
 10 psf TC Dead Load (includes future re-roofing)
 0 psf BC Live Load
 10 psf BC Dead Load
 40 to 70 psf Total Load (dependent on TC Live Load)

MiTEK FLOOR TRUSS MAX-SPANS

The chord max-spans shown on the next page are intended for use in bidding, estimating, and preliminary design applications. They are presented for six representative floor loadings. For proper interpretation of these max-spans, note the following:

- ◆ The max-spans are valid for the following (or better) species grades: No. 1 KD Southern Yellow Pine No. 1 and better Douglas Fir 2100F_b-1.8E Machine Stress Rated (MSR) lumber. Shorter spans will be achieved using lesser grade 4x2 lumber, while longer spans are generally possible with higher grade lumber.
- ◆ The max-spans represent truss overall lengths, assuming 3-1/2" bearing at each end. The spans are

equally valid for top chord-bearing and bottom chord-bearing support conditions.

- ◆ The minimum truss span-to-live load deflection is 360 for floor application. For example, the maximum permissible live load deflection for a 20' span floor truss is $(20 \times 12)/360 = 0.67"$.
- ◆ In addition to the consideration of lumber strength and deflection limitations, the maximum truss span-to-depth ratio is limited to 20 for floor loadings. For example the maximum span of a floor application truss 15" deep is $15" \times 20' = 300"$ span = 25' - 0" span.
- ◆ Floor loadings have included 1.00 Load Duration Increase and 1.15 Repetitive Stress Increase.

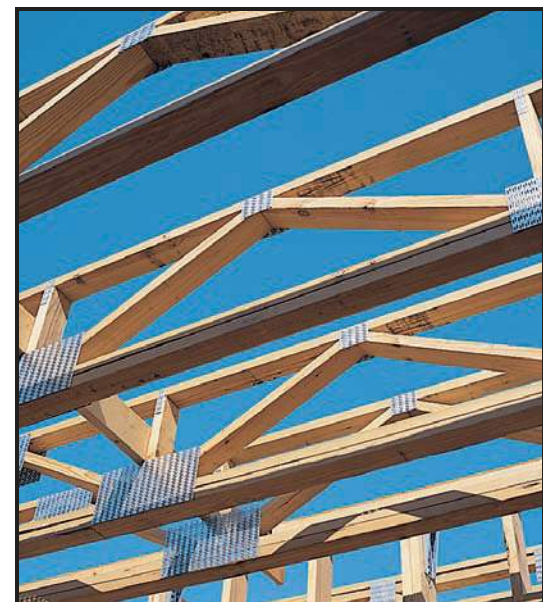

40/10/0/5 = 55 PSF @ 0%

Depth (inches)	24" o.c.	19.2" o.c.	16" o.c.	12" o.c.
12	17-11	20-03	20-06	20-06
13	18-09	21-02	22-02	22-02
14	19-17	22-01	23-11	23-11
15	20-04	22-11	25-03	25-07
16	21-01	23-09	26-02	27-04
17	21-09	24-07	27-01	29-00
18	22-06	25-04	27-11	30-09
20	23-10	26-10	29-07	34-02
22	25-01	28-03	31-02	36-03
24	26-03	29-07	32-07	37-11

40/10/0/10 = 60 PSF @ 0%

Depth (inches)	24" o.c.	19.2" o.c.	16" o.c.	12" o.c.
12	16-04	18-08	20-06	20-06
13	17-02	19-06	21-08	22-02
14	17-11	20-04	22-07	23-11
15	18-07	21-02	23-06	25-07
16	19-03	21-11	24-04	27-03
17	19-11	22-08	25-02	29-00
18	20-06	23-05	25-11	30-05
20	21-09	24-09	27-06	32-03
22	22-11	26-01	28-11	33-11
24	24-00	27-04	30-04	35-06

50/10/0/10 = 70 PSF @ 0%

Depth (inches)	24" o.c.	19.2" o.c.	16" o.c.	12" o.c.
12	15-02	17-03	19-02	20-06
13	15-10	18-01	20-00	22-02
14	16-06	18-10	20-11	23-11
15	17-02	19-07	21-09	25-06
16	17-10	20-04	22-06	26-05
17	18-05	21-00	23-03	27-04
18	19-00	21-08	24-00	28-02
20	20-02	22-11	25-05	29-10
22	21-02	24-02	26-09	31-05
24	22-02	25-04	28-01	32-11

40/25/0/10 = 75 PSF @ 0%

Depth (inches)	24" o.c.	19.2" o.c.	16" o.c.	12" o.c.
12	14-08	16-08	18-06	20-06
13	15-04	17-06	19-04	22-02
14	16-00	18-02	20-02	23-08
15	16-07	18-11	21-00	24-07
16	17-02	19-07	21-09	25-06
17	17-09	20-03	22-06	26-04
18	18-04	20-11	23-03	27-03
20	19-05	22-02	24-07	28-10
22	20-06	23-04	25-11	30-04
24	21-05	24-05	27-01	31-09

50/20/0/10 = 85 PSF 0%

Depth (inches)	24" o.c.	19.2" o.c.	16" o.c.	12" o.c.
12	13-09	15-08	17-05	20-05
13	14-05	16-05	18-02	21-04
14	15-00	17-01	19-00	22-03
15	15-07	17-09	19-09	23-02
16	16-02	18-05	20-05	23-11
17	16-08	19-00	21-02	24-09
18	17-03	19-08	21-10	25-07
20	18-03	20-10	23-01	27-01
22	19-03	21-11	24-04	28-06
24	20-02	22-11	25-06	29-10

50/35/0/10 = 95 @ 0%

Depth (inches)	24" o.c.	19.2" o.c.	16" o.c.	12" o.c.
12	13-00	14-10	16-05	19-03
13	13-07	15-06	17-02	20-02
14	14-02	16-02	17-11	21-00
15	14-09	16-10	18-08	21-11
16	15-03	17-05	19-04	22-08
17	15-10	18-00	20-00	23-05
18	16-04	18-07	20-07	24-02
20	17-03	19-08	21-10	25-07
22	18-02	20-09	23-00	26-11
24	19-00	21-09	24-01	28-03

Note:

Above max-spans are valid for lumber design only. Plating or other considerations may further limit the truss design.

4x2 Member A 2x4 lumber section used as a structural component oriented such that its 3-1/2" (4" nominal) face is horizontal.

Allowable Stress Increase A percentage increase in the stress permitted in a member, based on the length of time that the load causing the stress acts on the member. The shorter the duration of the load, the higher the percent increase in allowable stress.

Apez/Peak The uppermost point of a truss.

Axial Force A push (compression) or pull (tension) acting along the length of a member. Usually measured in pounds, kips (1,000 lbs.) or tons (2,000 lbs.), or metric equivalent.

Axial Stress The axial force acting at a point along the length of a member divided by the cross-sectional area of the member. Usually measured in pounds per square inch.

Balcony Cantilever A floor truss cantilever serving only as a balcony with no additional wall loading acting on the cantilever portion.

Battens/Purlins Timber sections spanning trusses to support roof covering.

Beam Pocket A rectangular opening within a truss to accept a header beam for positive load transfer.

Bearing A structural support, usually a wall, that occurs at the top or bottom chord or between the end points of a roof or floor truss.

Bending Moment A measure of the bending effect on a member due to forces acting perpendicular to the length of the member. The bending moment at a given point along a member equals the sum of all perpendicular forces, either to the left or right of the point, times their corresponding distances from the point.

Bending Stress The force per square inch of area acting at a point along the length of a member, resulting from the bending moment applied at that point. Usually measured in pounds per square inch or metric equivalent.

Bottom Chord The continuous 4x2 member forming the bottom of the truss.

Bottom Chord Bearing A floor truss support condition in which the truss load is transferred to the bearing or support through the bottom chord "sitting" on the support.

Butt Cut Slight vertical cut at the outside edge of truss bottom chord made to ensure uniform span and tight joints - usually 1/4 inch.

Camber An upward curvature built into a truss during fabrication to counteract downward deflection of the loaded truss.

Cantilever The portion of a truss extending beyond the exterior face of a support.

Chase The opening in some floor trusses or structural components in which the mechanical equipment (ducts, plumbing, etc.) runs, typically a rectangular opening at the centerline. (Also referred to as a Duct Opening.)

Check A lengthwise separation of wood fibers, usually extending across the rings of annual growth, caused chiefly by strains produced in seasoning.

Chord Splice A splice of the 4x2 chord member between joints, joined by pre-splice connector plates into the 3-1/2" faces and occasionally side plates into the 1-1/2" edges.

Clear Span Horizontal distance between interior edges of supports.

Combined Stress The combination of axial and bending stresses acting on a member simultaneously, such as occurs in the top chord (compression + bending) or bottom chord (tension + bending) of a truss.

Combined Stress Index (CSI) The summation of axial and bending stresses divided by their respective allowable stresses for a specific truss member. This ratio, or index, represents the structural "efficiency" of the member. The CSI shall not exceed 1.00.

Concentrated Load Loading applied at a specific point, such as a load-bearing wall running perpendicular to a truss, or a roof-mounted A/C unit hanging from a truss.

Connector Plate Pre-punched metal toothed connectors located at the joints and splices of a truss and designed to hold the forces which occur at those locations.

Cripple Rafter Infill rafter installed to continue the roof line - fixed to valley board in valley construction.

Dead Load Any permanent load such as the weight of roofing, flooring, sheathing, insulation or ceiling material, as well as the weight of the truss itself.

Design Loads The dead and live loads which a truss is engineered to support.

Deflection The maximum vertical displacement of a structural member due to applied loading. (Live load deflection is the displacement due to live load deflection.)

Depth The overall distance from the top of the top chord to the bottom of the bottom chord.

Dimensional Adjustment The adjustment necessary to alter standard repetitive floor truss panel modules to achieve the desired overall truss span. Dimensional adjustment

can be made at one end, both ends, or in the center. (Also referred to as Dimensional Take-Up.)

Doubled Chords The use of two 4x2 members along specified top or bottom chord panels to achieve added strength.

Dropped Cantilever The use of overlapping 4x2 floor truss top chord members to frame a balcony cantilever with a "step-down" of 1-1/2" or 3" to provide positive drainage or application of concrete deck.

End Detail Typically the location for dimensional adjustment. The end detail provides the support condition and necessary web orientation and panel length to create the desired truss span.

Engineer Certified Drawing A truss design where loading requirements, lumber species, sizes, grades and connector plate requirements are detailed and a certified engineer's seal is affixed.

Extended Top Chord Bearing A floor truss support condition in which the truss load is transferred to the support through the single or doubled top chord member extending to "sit" on the support. Popular for floor trusses used as roof purlins.

Fan Truss A floor truss with 30" top chord panels and 16" bottom chord panels and a fan web configuration.

Forces Axial compression or tension in structural components due to applied loads.

Girder A structural member carrying large loads due to attachment of headers or trusses framing into the girder (commonly called tie-in trusses).

Girder Truss Usually a multiple-ply truss designed to carry other trusses over an opening.

Header Beam A short beam typically supporting framing adjacent to a stair opening, running perpendicular to the floor trusses.

Header Truss A truss with 4x2 chords typically supporting roof, wall and/or upper floor loads, spanning over door or window openings. (For example, a garage door opening header truss.)

Heel Point on a truss at which the top and bottom chords intersect.

Heel Cut See Butt Cut.

Interior Bearing Any intermediate support condition in addition to the two exterior supports. A truss joint must be located above an interior bearing.

Jack Rafter Infill rafter installed to continue the roof line - fixed from wall plate to hip board in hip end construction.

Joint The intersection of two or more members. (Also referred to as a Panel Point.)

Joint Splice A splice of the 4x2 chord member at a chord-and-web joint.

Kneewall A short partition stud wall to increase a wall height, typically from the concrete wall plate to the floor decking.

Lateral Brace A member placed and connected at right angles to a chord or web member of a truss.

Level Return A lumber filler placed horizontally from the end of an overhang to the outside wall to form a soffit.

L/D Ratio The ratio of the truss span (L) to its depth (D), both dimensions in inches.

Live Load Any temporary applied load to a floor truss chord; typically roof live load is snow, while floor live loads are furniture, human occupancy, storage.

Load-Bearing Wall A wall specifically designed to transfer a roof load and/or upper floor load into the foundation.

Machine Stress Rated Lumber (MSR) Lumber which has been individually tested by a machine at the lumber mill to determine its structural design properties. MSR Lumber is designated by a flexural (bending) stress and Modulus of Elasticity, e.g., 1650F-1.5E.

Moisture Content of Wood The weight of the moisture in wood expressed as a percentage of its oven-dry weight.

Moments A structural measure of the effects of bending on a member due to applied loading.

Overall Rise Vertical distance from bottommost part of the bottom chord to uppermost point on peak.

Overhang The extension of the top chord of a truss beyond the heel measured horizontally.

PCT Abbreviation for Parallel Chord Truss, the Truss Plate Institute (TPI) specification designation for trusses with parallel chords and 4x2 chord orientation, titled "Design Specification for Metal Plate Connected Parallel Chord 4x2 Wood Trusses".

PLF Pounds per lineal foot, acting along a structural member, usually equal to the uniform load (PSF) times the truss spacing.

PSF Pounds per square foot of uniform load.

Panel Length The distance between the centerlines of two consecutive joints along the top or bottom chord.

Panel The chord segment defined by two adjacent joints.

Panel Point The point where a web or webs intersect a chord.

Typical Floor Truss

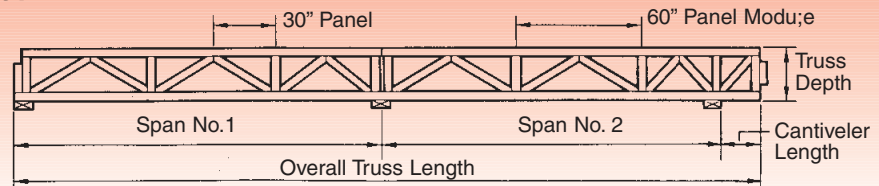

Peak Point on truss where the sloped top chords meet.

Pitch Inches of vertical rise for each 12 inches of horizontal run.

Plate A horizontal wood framing member, typically the top and bottom 2x4 members of a stud wall and the 2x6 sill plate bolted to a concrete wall for floor structural attachment.

Plenum Typically, the use of the entire floor truss cavity formed by the floor above and the ceiling below as a supply or return air "duct".

Plumb Cut Top chord end cut to provide for vertical (plumb) installation to fascia (face trim board).

Plumb Rise Vertical overall measurements at the end of a truss where the top and bottom chords meet.

Pre-Splice Plates Connector Plates pressed into the top and bottom 3-1/2" faces of two 4x2 chord members prior to final floor truss assembly to achieve a structural chord splice.

Purlins Secondary structural components, spanning between primary structural members and supporting the decking.

1/4 Point point on triangular, Fink or Howe truss where the webs connect to the top chord.

1/3 Point Point on triangular, Fink truss where the webs connect to the bottom chord.

Reaction The total load transferred from the uniform load (PSF) applied to the floor truss deck, then into the floor truss, and ultimately, to the floor truss bearing or support.

Ridge Line formed by truss apexes.

Rim Joist An exterior transition member supporting the decking edge and wall sheathing, usually tying the ends of floor trusses together. (Also referred to as a Ribbon or Band Board.)

Rise Vertical distance from bottom most part of the bottom chord to inside of the peak.

Scab Additional timber connected to a truss to effect a splice, extension or general reinforcement.

Shop Drawing Detailed drawings of a roof truss or roof framing showing critical dimensions such as span, overhang, cantilever, slope, etc.

Slope See Pitch.

Spacing The centerline-to-centerline distance between trusses.

Span The overall distance between adjacent interior supports or to the outside of supports when at the end of a truss. (See detail above.)

Splice Point (Top & Bottom chord splice). The point at which two chord members are joined together to form a single member. It may occur at a panel point or between panel points.

Square Cut End of top chord cut perpendicular to slope of the member.

Strongback A 2x6 lateral brace, used with its long dimension in a vertical orientation, running perpendicular to the trusses, and attached to the truss vertical web members.

Support The structural element resisting the truss, usually a wall or beam. (Also referred to as a Bearing.)

Symmetrical Truss Truss with the same configuration of members and design loading occurring on each side of truss centerline.

Top Chord The continuous 4x2 member forming the top of the floor truss.

Top Chord Bearing A floor truss support condition in which the truss load is transferred to the bearing or support through the top chord and 4x4 block end detail.

When the 4x4 block length is extended, this is referred to as Mid-Chord Bearing.

Truss A pre-built component that functions as a structural support member. A truss employs one or more triangles in its construction.

Truss-clip Metal component designed to provide structural connection of trusses to wall plates to resist wind uplift forces.

Visual Grade Lumber Lumber which has been visually rated at the lumber mill for structural properties through rules established by national lumber species associations.

Warren Truss A general truss configuration with repetitive web "W" orientation. For floor truss applications, the top and bottom chord panels are typically 30" length, usually with a 24" wide rectangular chase or duct opening at the centerline.

Web A vertical or inclined member connecting the top and bottom chords of a truss.

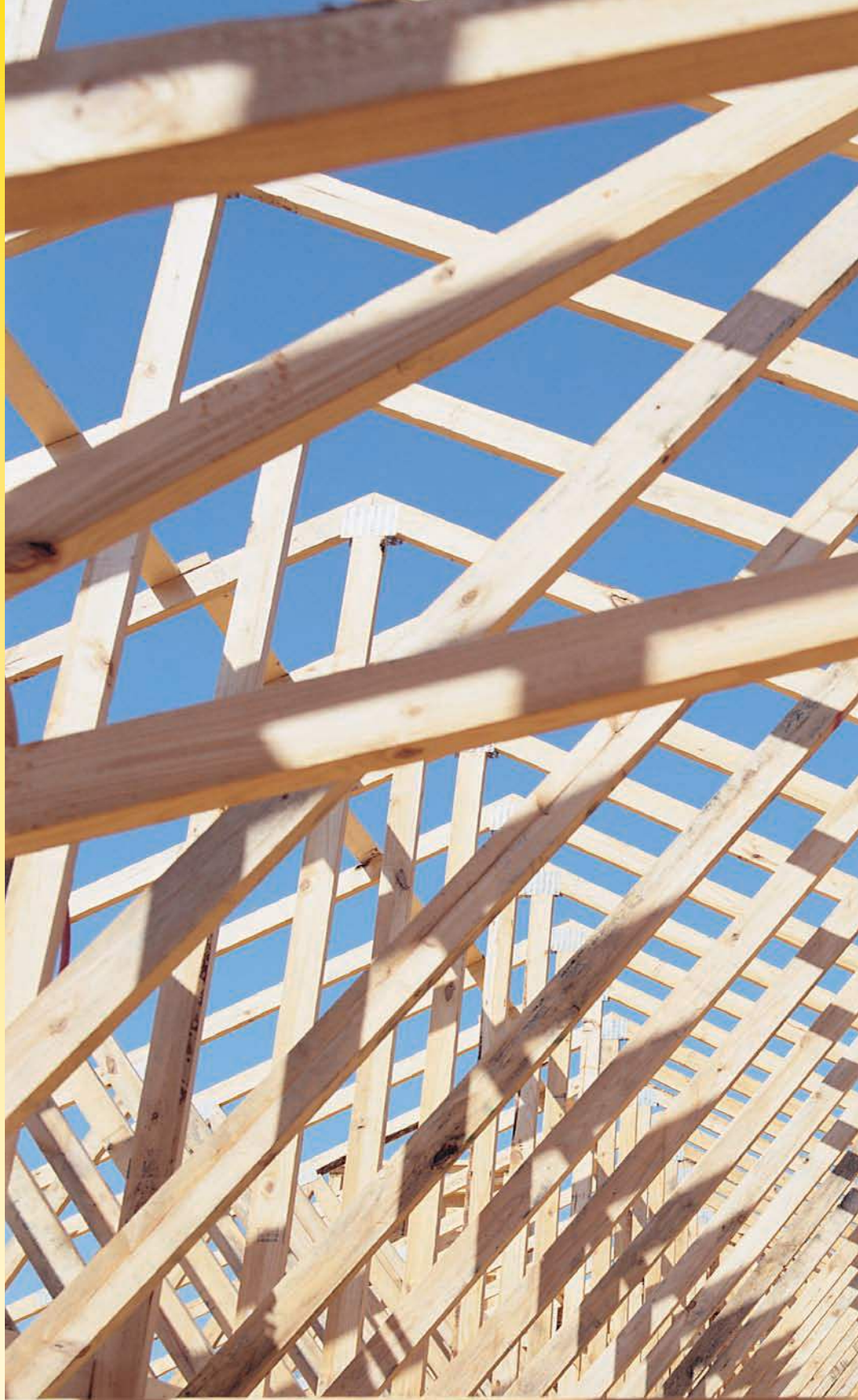

MiTek Industries, Inc.
14515 N. Outer Forty Suite 300
Chesterfield MO 63017
800.325.8075 • (Fax) 314.434.5343
www.mii.com